

Majestic Series Milk Dispensers

Models: SKMAJ1, SKMAJ2, SKMAJ3



Silver King® is the leader in reliable and energy efficient refrigeration solutions. Our sleek, stainless steel milk dispensers are made with the highest quality materials to guarantee everything is kept fresh and meets temperature standards. Our milk dispensers have polyurethane insulation for maximum strength and durability, and minimal energy waste.

Standard Features

- Exterior stainless steel with galvanized bottom reduces risk of corrosion.
- Interior stainless steel, covered corners and finished edges for easy cleaning.
- Environmentally friendly polyurethane foamed-in-place insulation for maximum strength and durability.
- Standard 8 foot 3 wire power cord NEMA 5-15P plug.
- Door has heavy duty hinges and has a removable gasket for ease of cleaning.
- Spring loaded lift type valve for dripless operation and optimum sanitation.
- CFC-free, 134A refrigerant, hermetically sealed, high efficiency, self contained refrigeration system.
- Limited Warranty: 1-year labor, 1-year parts, 5-year compressor (part only), 90-days replacement parts. Warranty is determined by the original equipment manufacturing date for general market.*

Specifications

SKMAJ1, SKMAJ2, SKMAJ3

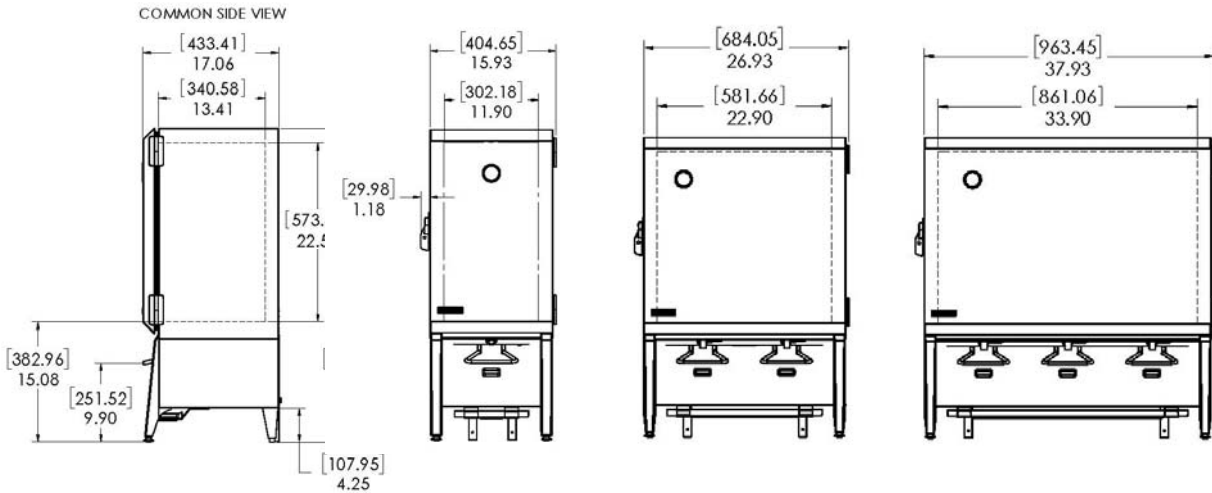

DIMENSIONS

C4 SERIES: Includes 6 gallon crate(s) and platform(s)

Model Number	Capacity	Width in (mm)	Height in (mm)	Depth in (mm)	Gross Shipping Weight lb (kg)	Unit Net Weight lb (kg)	Shipping cu ft (cu m)
SKMAJ1/C4	Single valve	15.93	39.50	17.06	120	110	18.06
	6 gallons	(404.65)	(1003.31)	(433.41)	(54.0)	(49.9)	(.51)
SKMAJ2/C4	Double valve	26.93	39.50	17.06	160	145	26
	12 gallons	(684.05)	(1003.31)	(433.41)	(73.0)	(65.77)	(.74)
SKMAJ3/C4	Triple valve	37.93	39.50	17.06	200	180	33.91
	18 gallons	(963.45)	(1003.31)	(433.41)	(90.72)	(81.65)	(.96)

C3 SERIES: Includes 6 gallon crate(s), platform(s), and shipboard legs

Model Number	Capacity	Width in (mm)	Height in (mm)	Depth in (mm)	Gross Shipping Weight lb (kg)	Unit Net Weight lb (kg)	Shipping cu ft (cu m)
SKMAJ1/C3	Single valve	15.93	39.50	17.06	120	110	18.06
	6 gallons	(404.65)	(1003.31)	(433.41)	(54.0)	(49.9)	(.51)
SKMAJ2/C3	Double valve	26.93	39.50	17.06	160	145	26
	12 gallons	(684.05)	(1003.31)	(433.41)	(73.0)	(65.77)	(.74)
SKMAJ3/C3	Triple valve	37.93	39.50	17.06	200	180	33.91
	18 gallons	(963.45)	(1003.31)	(433.41)	(90.72)	(81.65)	(.96)

Electrical

Model Number	Country of Origin	Amps	Voltage	Hz	Plug
SKMAJ1/C4	USA	1.5	120 VAC	60 Hz	1 Ph.— NEMA 5-15P
SKMAJ2/C4	USA	1.4	120 VAC	60 Hz	1 Ph.— NEMA 5-15P
SKMAJ3/C4	USA	1.9	120 VAC	60 Hz	1 Ph.— NEMA 5-15P

Model Number	Country of Origin	Amps	Voltage	Hz	Plug
SKMAJ1/C3	USA	1.5	120 VAC	60 Hz	1 Ph.— NEMA 5-15P
SKMAJ2/C3	USA	1.4	120 VAC	60 Hz	1 Ph.— NEMA 5-15P
SKMAJ3/C3	USA	1.9	120 VAC	60 Hz	1 Ph.— NEMA 5-15P

Accessories



Milk Crate for
3, 5, or
6 Gallon bags
Item #35904



3 Gallon
Milk Can
Item #62642



5 Gallon
Milk Can
Item #60224



Platform for
bag-in-box
Item #63959

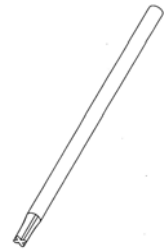

Milk tubes
Item #20323

Certifications



Shipboard Legs
Item #10314-96

